

# GECE



0.8 TON



VOICE CONTROL



REMOTE

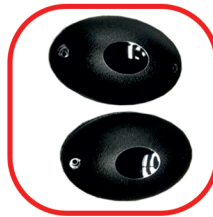

OPTICAL SENSOR



APP CONTROL



IP67

## Technical Specification

T24GECE800M



1. Working Voltage : 220V/50 Hz AC/110V/60 Hz AC/380V/50 HzAC
2. Motor Power : 0.37-1.5KW
3. Starting Current : 3 A
4. Motor Speed : 1400r/min
5. Running Speed : 12m/min
6. Applicable Door Weight : 800 Kg
7. Working Temperature : -40°C - +60°C
8. Machine Net Weight : 38 Kg
9. Reserved Cable Installation : 1mm<sup>2</sup> x 6-core (or 1.5 m<sup>2</sup> x 2-core) Cable



## Product Specification

Maximum Output Current : 10V

Fuse : AC220V 10 A

Remote Control Distance : Open Area > 30 Meters

Relative Humidity : <60%

## Special Functions

One Key Mode / 4 Key Mode

Easy Lock Functions on remote

Auto Closing

Slow Stop Function

Resistance Function

Closing Distance Learning Algorithm

Master Salve Function (Dual Motor Synchronous)

Motor Rotation Direction Conversion

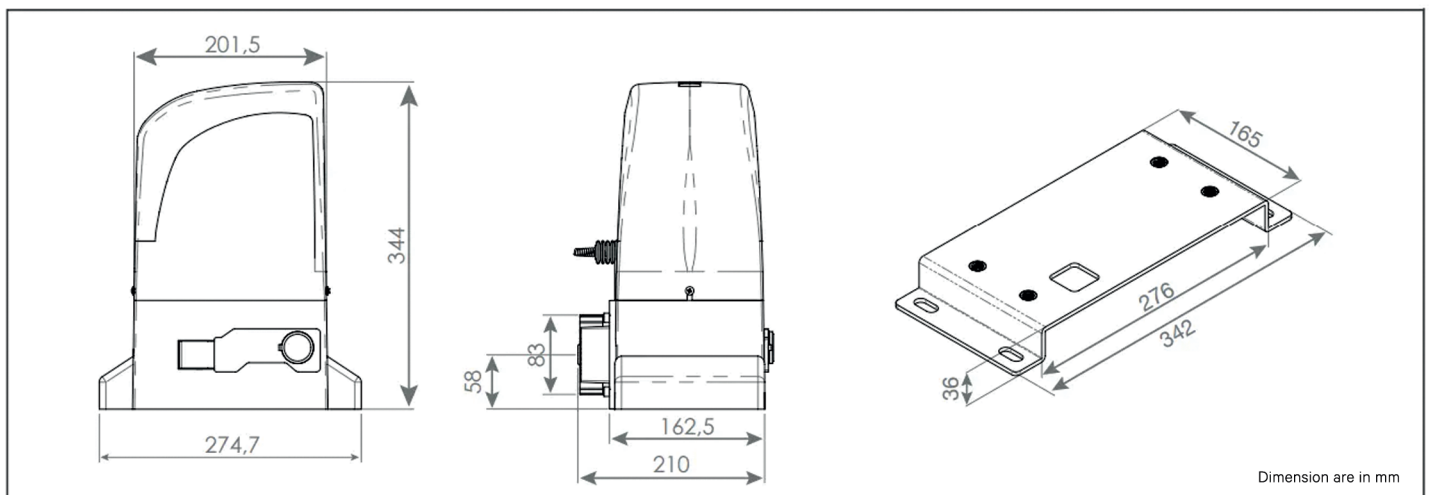

## Headquarters

Kontakt

GECE Zentrale

+49-7152-203-0

Mo – Do: 7.30 – 17.00 Uhr / Fr: 7.30 – 16.00 Uhr

GECE Service Zentrale

+49-7152-9233-0

GECE 24h Service Hotline

+49-1802-9233-92

(0,06 € pro Anruf aus allen deutschen Netzen)

Germany

