



0.4 TON EACH



VOICE CONTROL



REMOTE



OPTICAL SENSOR



APP CONTROL



IP67



Year  
WARRANTY

## Technical Specification

S24GECE1200M2



1. Working Voltage : 220V/50 Hz AC/110V/60 Hz AC/380V/50 HzAC or DC 24 V
2. Motor Power : 100 W
3. Running Speed : 2600r/min
4. Applicable Door Weight : 800 Kg
5. Working Temperature : -25°C - +65°C
6. Machine Net Weight : 30 Kg
7. Reserved Cable Installation : 1mm<sup>2</sup> x 6-core (or 1.5 m<sup>2</sup> x 2-core) Cable
8. Output Torque : 2500N.m



## Product Specification

Open Thrust : 500 N

Lifting Range : 0~250mm

Remote Control Distance : Open Area > 30 Meters

Relative Humidity : <60%

## Special Functions

One Key Mode / 4 Key Mode

Easy Lock Functions on remote

Single Leaf or Double Leaf Opening

Automatic Detection and Protection

Access Control

Gate Operating Indication

Backup Battery Interface

Gate Opening Angle and Sequence can be set

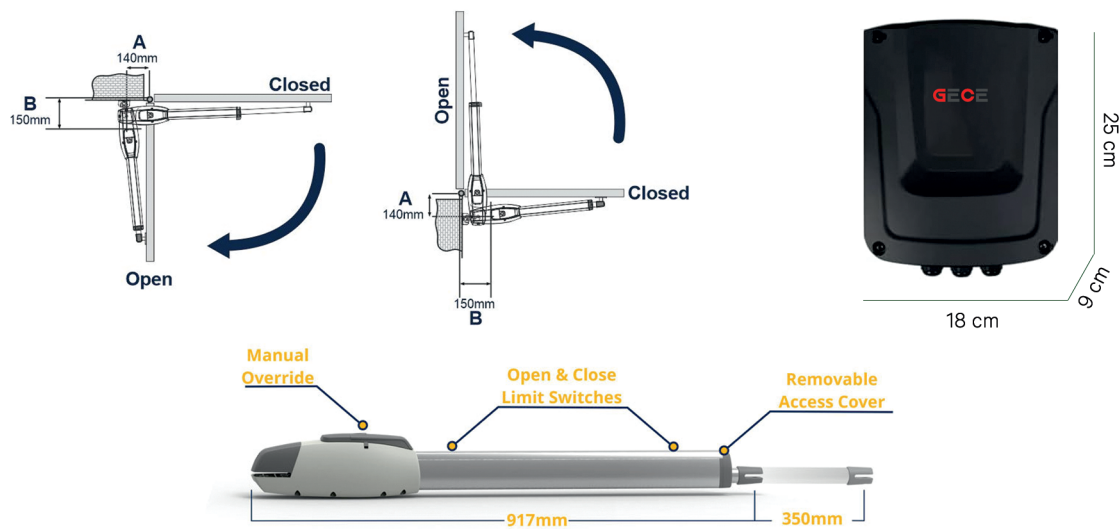

## Headquarters

Contact

GECE Central

+49-7152-203-0

Mo–Thu: 7.30 a.m. – 5 p.m. / Fri: 7.30 a.m. – 4 p.m.

GECE Service Central

+49-7152-9233-0

GECE 24h Service Hotline

+49-1802-9233-92

(0,06 € / Calling from all German networks)

Germany

